



TITLE:

**SPECIFICATION FOR LOW
VOLTAGE INSULATORS
(Shackle Insulators, LV)**

Doc. No. KPLC1/3CB/TSP/04/011

Issue No. 1

Revision No. 2

Date of Issue 2015-05-18

Page 1 of 11

TABLE OF CONTENTS

0.1 Circulation List

0.2 Amendment Record

FOREWORD

1. SCOPE
2. REFERENCES
3. TERMS AND DEFINITIONS
4. REQUIREMENTS
5. TESTS AND INSPECTION
6. MARKING, LABELLING AND PACKING

ANNEX A: *Guaranteed Technical Particulars (to be filled and signed by the Manufacturer and submitted together with relevant copies of the Manufacturer's catalogues, brochures, drawings, technical data, sales records for past five years, four customer reference letters, details of manufacturing capacity, the manufacturer's experience, copies of complete type test reports and accreditation certificate to ISO/IEC 17025 for the third party testing laboratory for tender evaluation, all in English Language)*

Issued by: Head of Section, Standards Development

Authorized by: Head of Department, Standards

Signed:

Signed:

Date: 2015-05-18

Date: 2015-05-18



TITLE:
SPECIFICATION FOR LOW VOLTAGE INSULATORS (Shackle Insulators, LV)

Doc. No.	KPLC1/3CB/TSP/04/011
Issue No.	1
Revision No.	2
Date of Issue	2015-05-18
Page 2 of 11	

0.1 Circulation List

COPY NO.	COPY HOLDER
1	Standards Manager
Electronic copy (pdf) on Kenya Power Server (http://172.16.1.40/dms/browse.php?fFolderId=23)	

0.2 Amendment Record

Rev No.	Date (YYYY-MM-DD)	Description of Change	Prepared by (Name & Signature)	Approved by (Name & Signature)
Issue 1 Rev 1	2010-04-16	Revised requirements on marking & GTP	S Kimitei	G Owuor
Issue 2 Rev 0	2015-05-18	Cancel and replaces Issue 1 Rev 1 dated 2010-04-16 & all previous issues	Nancy Wairimu	Dr. Eng. Peter Kimemia

FOREWORD

Issued by: Head of Section, Standards Development

Authorized by: Head of Department, Standards

Signed:

Signed:

Date: 2015-05-18

Date: 2015-05-18



TITLE:

SPECIFICATION FOR LOW VOLTAGE INSULATORS (Shackle Insulators, LV)

Doc. No.	KPLC1/3CB/TSP/04/011
Issue No.	1
Revision No.	2
Date of Issue	2015-05-18
Page 3 of 11	

FOREWORD

This specification has been prepared by the Standard Department of The Kenya Power and Lighting Company Limited (KPLC) and it lays down requirements for low voltage (shackle) insulators. It is intended for use by KPLC in purchasing the low voltage (shackle) insulators.

The manufacturer shall submit information which confirms satisfactory service experience with products which fall within the scope of this specification.

1. SCOPE

- 1.1. This specification is for low voltage (shackle) insulators for use on overhead power distribution lines operating at voltage U/U_m of 600/1000 Volts and frequency of 50Hz.
- 1.2. The specification also covers inspection and test of the low voltage (shackle) insulators as well as schedule of Guaranteed Technical Particulars to be filled, signed by the manufacturer and submitted for tender evaluation.
- 1.3. The specification stipulates the minimum requirements for low voltage (shackle) insulators acceptable for use in the company (KPLC) and it shall be the responsibility of the Manufacturer to ensure adequacy of the design, good workmanship and good engineering practice in the manufacture of the low voltage (shackle) insulators for KPLC.
- 1.4. The specification does not purport to include all the necessary provisions of a contract

2. REFERENCES

The following standards contain provisions which, through reference in this text constitute provisions of this specification. Unless otherwise stated, the latest editions (including amendments) apply.

- IEC 60383-1: Insulators for overhead lines with nominal voltage above 1000V- Part 1: Ceramic or glass insulator units for a.c. systems – Definitions, test methods and acceptable criteria.
- IEC 60672-2 &3: Ceramic and glass insulating materials – part 2: methods of test;- part 3: specification for individual materials.
- IEC 60071-1: Insulation co-ordination – part 1: Definitions, principles and rules.
- ENA TS 43-93: Line insulators.
- RAL : Colour chart.

Issued by: Head of Section, Standards Development

Authorized by: Head of Department, Standards

Signed:

Signed:

Date: 2015-05-18

Date: 2015-05-18



TITLE:

SPECIFICATION FOR LOW VOLTAGE INSULATORS (Shackle Insulators, LV)

Doc. No.	KPLC1/3CB/TSP/04/011
Issue No.	1
Revision No.	2
Date of Issue	2015-05-18
Page 4 of 11	

IEC 60815: Selection and dimensioning of high-voltage insulators intended for use in polluted conditions – Part 1: Definitions, information and general principles

3. TERMS AND DEFINITIONS

For the purpose of this specification the definitions given in the reference standards shall apply.

4. REQUIREMENTS

4.1 SERVICE CONDITIONS

The low voltage (shackle) insulator shall be designed and constructed for continuous outdoor operation in tropical areas and harsh climatic conditions including areas exposed to:

- a) Sea spray along the coast, with SPS class d (heavy), Example E5 as per IEC 60815;
- b) Humidity up to 90%;
- c) Average ambient temperature of +30°C with minimum of -1°C and a maximum of +40°C and
- d) Altitudes of not more than 2200m above sea level.

4.2. MATERIALS AND CONSTRUCTION

4.2.1. The insulating material shall be made from grade C- 120 ceramic material or equivalent complying to IEC 60627-3 standard and shall have the following properties:

Table 1: Properties of grade C-120 ceramic material (Aluminous porcelain)

properties	Unit	C-120
Maximum open (apparent) porosity	Vol %	0.0
Minimum bulk density	Mgm ⁻³	2.3
Minimum flexural strength (glazed)	MPa	110
Minimum resistance to thermal shock	K	150
Minimum electric strength	kV mm ⁻¹	20
Minimum withstand voltage	kV	30
Maximum dissipation factor at 20°C (48 Hz to 62Hz)	10 ⁻³	25
Minimum volume of resistivity in terms of temperature(dc) at 30°C	Ωm	10 ¹¹

4.2.2. The porcelain shall be sound, free from flaws and blemishes, smoothly glazed and of uniform brown colour complying to RAL 8016 as per RAL colour chart when finished.

Issued by: Head of Section, Standards Development

Authorized by: Head of Department, Standards

Signed:

Signed:

Date: 2015-05-18

Date: 2015-05-18

TITLE:

SPECIFICATION FOR LOW VOLTAGE INSULATORS (Shackle Insulators, LV)

Doc. No.	KPLC1/3CB/TSP/04/011
Issue No.	1
Revision No.	2
Date of Issue	2015-05-18
Page 5 of 11	

- 4.2.3. The low voltage (shackle) insulator shall be made from moulding technique and turning. This shall ensure tolerance to DIN 40680 standard.
- 4.2.4. The low voltage (shackle) insulator shall be free from stresses due to expansion and contraction in any part which may lead to deterioration.
- 4.2.5. The hole in the low voltage (shackle) insulator shall be smoothly radiused to present an even bearing surface to the steel bolt.
- 4.2.6. The low voltage (shackle) insulator shall be of reel type in accordance with Fig.1 and provisions of ENA TS 43-93 standard in terms of design and dimensions.

4.3. GENERAL CHARACTERISTICS

The dimensional, mechanical and electrical characteristics of the low voltage (shackle) insulator shall be as shown in Fig. 1 and table 2:-

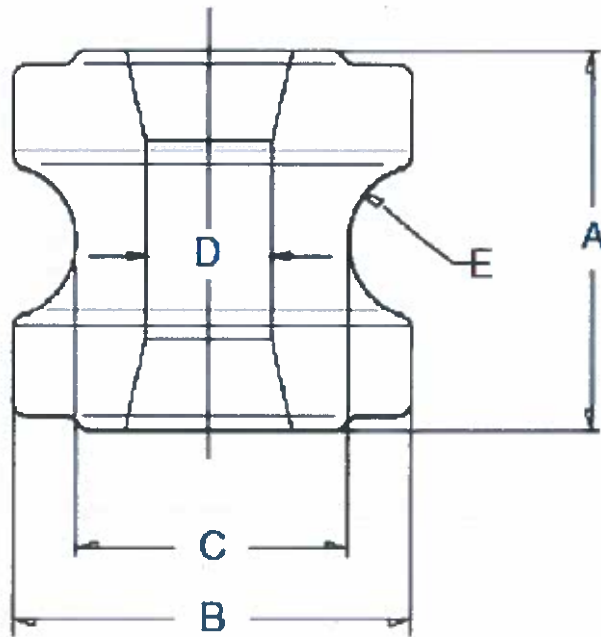



Fig. 1: A typical low voltage insulator (shackle insulator)

Issued by: Head of Section, Standards Development	Authorized by: Head of Department, Standards
Signed: 	Signed: 
Date: 2015-05-18	Date: 2015-05-18



TITLE:
SPECIFICATION FOR LOW VOLTAGE INSULATORS (Shackle Insulators, LV)

Doc. No.	KPLC1/3CB/TSP/04/011
Issue No.	1
Revision No.	2
Date of Issue	2015-05-18
Page 6 of 11	

Table 2: General Characteristics of a low voltage (shackle) insulator

Dimensions			Tolerance as per DIN 40680	
	Height (A)	65mm	± 2%	
	Diameter (B)	76mm		
	Diameter (C)	44mm		
	Diameter (D)	17.5mm	± 0.45%	
	Conductor groove radius (E)	9.5mm	± 0.30%	
Electrical characteristics				
Minimum	Power frequency flashover voltage (wet)	10kV		
	Power frequency flashover voltage (dry)	20kV		
	Nominal specific creepage distance	25mm/kV ²		
Mechanical characteristics				
	Minimum falling load	15kN		
Weight				
	Maximum weight per piece	0.5kg		

4.4. QUALITY MANAGEMENT SYSTEM

- 4.4.1. The supplier shall submit a quality assurance plan (QAP) that will be used to ensure that the requirements will fulfill the requirements stated in the contract documents, standards, specifications and regulations.
- 4.4.2. The Manufacturer's Declaration of Conformity to applicable standards and copies of quality management certifications shall be submitted with the tender for evaluation.

5. TESTS AND INSPECTION

- 5.1. The finished low voltage (shackle) insulator shall be inspected and tested in accordance with IEC 60383-1, IEC 60672-2 & 3, IEC 60071-1, ENA TS 43-93 standards and all provisions of this specification . It shall be the responsibility of the manufacturer to perform or to have performed all the tests specified.
- 5.2. Copies of previous Test Reports conforming to clause 4 requirements for the low voltage (shackle) insulator, issued by a third party testing laboratory that is accredited to ISO/IEC 17025 shall be submitted with the tender for the purpose of technical evaluation. The accreditation certificate for the third party testing laboratory shall also be submitted with the tender (all in English Language).Copies of type test reports to be submitted with the tender (by the bidder) for evaluation shall be as stated below:

- a) Verifications of dimensions and weight;
- b) Mechanical falling load;

Issued by: Head of Section, Standards Development	Authorized by: Head of Department, Standards
Signed:	Signed:
Date: 2015-05-18	Date: 2015-05-18



TITLE:

SPECIFICATION FOR LOW VOLTAGE INSULATORS (Shackle Insulators, LV)

Doc. No.	KPLC1/3CB/TSP/04/011
Issue No.	1
Revision No.	2
Date of Issue	2015-05-18
Page 7 of 11	

- c) Porosity test;
- d) Wet power frequency flashover voltage test;
- e) Dry power frequency flashover voltage test;
- f) Flexural strength test;
- g) Electric strength test;
- h) Bulk density test;
- i) Voltage withstand test;
- j) Dissipation factor at 20°C;
- k) Volume of resistivity at 30°C.

NOTE: Any translations of certificates and test reports into English language shall be signed and stamped by third party testing laboratory that carried out the tests.

5.3. The low voltage (shackle) insulator shall be subject to acceptance tests at the manufacturer's works before dispatch. Acceptance tests shall be witnessed by two engineers appointed by the Kenya Power and Lightning Company Limited (KPLC). Routine and sample Test Reports for the low voltage (shackle) insulators to be supplied shall be submitted to KPLC for approval before deliver of the goods.

5.4. Tests to be witnessed by KPLC Engineers at the factory shall be in accordance with IEC 60383-1, IEC 60672-2 &3, IEC 60071-1, ENA TS 43-93 standards and all provisions of this specification and shall include:

- a) Verifications of dimensions and weight;
- b) Mechanical falling load;
- c) Wet power frequency flashover voltage test;
- d) Dry power frequency flashover voltage test;
- e) Electric strength test;
- f) Voltage withstand test;

5.5. On receipt of the low voltage (shackle) insulator KPLC will inspect them and may perform any of the relevant tests in order to verify compliance with the specification. The manufacturer shall replace without charge to KPLC, low voltage (shackle) insulators which upon examination, test or use fail to meet any or all of the requirements in the specification.

6. MARKING AND PACKING

6.1 MARKING

The following information shall be marked indelibly and legibly on the porcelain portion of each low voltage (shackle) insulator in English language:

- a) Name or trademark of the manufacturer;
- b) Reference number and specified mechanical falling load;
- c) Year of Manufacture;
- d) Batch or serial number;
- e) The letters "Property of KPLC".

Issued by: Head of Section, Standards Development	Authorized by: Head of Department, Standards
Signed:	Signed:
Date: 2015-05-18	Date: 2015-05-18



TITLE:
SPECIFICATION FOR LOW VOLTAGE INSULATORS (Shackle Insulators, LV)

Doc. No.	KPLC1/3CB/TSP/04/011
Issue No.	1
Revision No.	2
Date of Issue	2015-05-18
Page 8 of 11	

6.2 PACKAGING

- 6.2.1. The low voltage (shackle) insulators shall be packed in wooden crates which are reinforced and held closed by external steel bands. Each crate shall be internally braced to permit stacking and the steel wire bindings shall be designed to keep the crate firmly closed and permit easy and rapid opening at time of installation.
- 6.2.2. The crates shall then be stacked on sturdy wood pallet. The assembly shall be held tightly in place with steel bands and protected against moisture by a complete covering of heat-shrinkable polyethylene film.
- 6.2.3. Instructions for storage, handling and installation shall be included in each package, all in English Language.

7.0. DOCUMENTATION

7.1 The bidder shall submit its tender complete with technical documents required by Annex A (Guaranteed Technical Particulars) for tender evaluation. The documents to be submitted (all in English language) for tender evaluation shall include the following:

- a) Guaranteed Technical Particulars fully filled and signed by the manufacturer;
- b) Copies of the Manufacturer's catalogues, brochures, drawings and technical data;
- c) Sales records for previous five years and reference letters from at least four of the customers;
- d) Details of manufacturing capacity and the manufacturer's experience;
- e) Copies of required type test certificates and type test reports by a third party testing laboratory accredited to ISO/IEC 17025;
- f) Copy of accreditation certificate to ISO/IEC 17025 for the third party testing laboratory;
- g) Manufacturer's warranty and guarantee;
- h) Manufacturer's letter of authorization, copy of the manufacturer's ISO 9001:2008 certificate and other technical documents required in the tender.

7.2 The successful bidder (supplier) shall submit the following documents/details (from the manufacturer as per tender) to The Kenya Power & Lighting Company for approval before manufacture:

- a) Guaranteed Technical Particulars fully filled and signed by the manufacturer;
- b) Design drawings & construction details of the low voltage (shackle) insulators including 3-D views;
- c) Quality assurance plan (QAP) that will be used to ensure that the design, material, workmanship, tests, service capability, maintenance and documentation will fulfill the requirements stated in the contract documents, standards, specifications and regulations.

Issued by: Head of Section, Standards Development	Authorized by: Head of Department, Standards
Signed: 	Signed: 
Date: 2015-05-18	Date: 2015-05-18



TITLE:

SPECIFICATION FOR LOW VOLTAGE INSULATORS (Shackle Insulators, LV)



Doc. No.	KPLC1/3CB/TSP/04/011
Issue No.	1
Revision No.	2
Date of Issue	2015-05-18
Page 9 of 11	

The QAP shall be based on and include relevant parts to fulfill the requirements of ISO 9001:2008;

- d) Test Program to be used after manufacture;
- e) Marking details and method to be used in marking each low voltage (shackle) insulator;
- f) Manufacturer's undertaking to ensure adequacy of the design, adherence to applicable regulations, standards and specification, ensure good workmanship and good engineering practice in the manufacture of the low voltage (shackle) insulators for The Kenya Power and Lighting Company Limited;
- g) Packaging details (including packaging materials and marking and identification of component packages).

NOTE: *The drawings to be submitted by the supplier to KPLC for approval before manufacture shall be in standard format clearly indicating drawing number, parts list with material details & quantities, standard of manufacture, ratings, approval details and identity of the manufacturer (as per manufacturer's authorization submitted during tendering).*

.....THIS SPACE LEFT BLANK.....

Issued by: Head of Section, Standards Development	Authorized by: Head of Department, Standards
Signed: 	Signed: 
Date: 2015-05-18	Date: 2015-05-18



TITLE:
SPECIFICATION FOR LOW VOLTAGE INSULATORS (Shackle Insulators, LV)

Doc. No.	KPLC1/3CB/TSP/04/011
Issue No.	1
Revision No.	2
Date of Issue	2015-05-18
Page 10 of 11	

ANNEX A: Guaranteed Technical Particulars (to be filled and signed by the Manufacturer and submitted together with relevant copies of the Manufacturer's catalogues, brochures, drawings, technical data, sales records for past five years, four customer reference letters, details of manufacturing capacity, the manufacturer's experience, copies of complete type test reports and accreditation certificate to ISO/IEC 17025 for the third party testing laboratory for tender evaluation, all in English Language)

TENDER NO

Clause	Description	KPLC REQUIREMENTS	Bidders offer (indicate full details of the values offered)
	Name of Manufacturer		state
	Country of manufacture		State
	Type/Model Reference Number		State
1	Scope		state
2	Design standards complied with		state
3	Terms and Definitions		state
4	Requirements		
4.1	Service condition		state
	Insulator colour	RAL 8016	
	Maximum open (apparent) porosity	0.0%	
	Minimum bulk density	2.3	
	Minimum flexural strength (glazed)	110	
	Minimum resistance to thermal shock	150	
	Minimum electric strength	20	
	Minimum withstand voltage	30	
	Maximum dissipation factor at 20°C (48 Hz to 62Hz)	25	
	Minimum volume of resistivity in terms of temperature(dc) at 30°C	10 ¹¹	
4.3	General characteristics		
	Dimensions		
	Height (A)	65mm (±2%)	
	Diameter (B)	76mm (±2%)	
	Diameter (C)	44mm (±2%)	
	Diameter (D)	17.5mm (±0.45%)	
	Conductor groove radius (E)	9.5mm (±0.3%)	
	Electrical characteristics		
	Min. Nominal specific creepage distance	25kV/mm ²	

Issued by: Head of Section, Standards Development

Authorized by: Head of Department, Standards

Signed:

Signed:

Date: 2015-05-18

Date: 2015-05-18



TITLE:

SPECIFICATION FOR LOW VOLTAGE INSULATORS (Shackle Insulators, LV)

Doc. No.	KPLC1/3CB/TSP/04/011
Issue No.	1
Revision No.	2
Date of Issue	2015-05-18
Page 11 of 11	

	Min. wet power frequency withstand voltage	10kV	
	Min. dry power frequency withstand voltage	20kV	
Mechanical characteristics			
	Minimum falling load	15kN	
	Maximum weight per piece	0.5 kg	
4.5.	Quality Management System		
	Quality Assurance Plan		provide
	Copy of ISO 9001:2008 Certificate		provide
5.1	Test standards and responsibility of carrying out tests		provide
5.2	Copies of Type Test Reports submitted with tender		provide
5.3	Acceptance tests to be witnessed by KPLC engineers at the factory before shipment		provide
5.4	Test reports to be submitted by supplier to KPLC for approval before shipment		
5.5	Replacement of rejected low voltage (shackle) insulators.		specify
6.1	Marking		specify
6.2	Packing		specify
7.1	Documents submitted with tender		provide
7.2	Documents to be submitted by supplier to KPLC for approval before manufacture		provide
8.0	Manufacturer's Guarantee and Warranty		provide
9.0	List catalogues, brochures, technical data and drawings submitted to support the offer		provide
10.0	List customer sales records and reference letters submitted to support the offer.		provide
11.0	List Test Certificates submitted with tender		provide
12.0	List test reports of the wrenches to be submitted to KPLC for approval before shipment		provide
13.0	Statement of compliance to specification (indicate deviations if any & supporting documents)		provide

NOTE:

- 1) Bidders shall give full details and the offered values of the items on order as per Annex A. The details provided shall conform to the test reports and their certificates as required by clause 5.2., well labeled drawings complete with dimensions, catalogues or brochures for the purpose of tender evaluation.
- 2) Bidder who shall have not complied by this requirement in bullet 1 shall be automatically disqualified from bidding this item.

.....
Manufacturer's Name, Signature, Stamp and Date

Issued by: Head of Section, Standards Development

Authorized by: Head of Department, Standards

Signed:

Signed:

Date: 2015-05-18

Date: 2015-05-18

Handwritten marks at the top right corner.

